

# K-Band VCO Calibration Procedure

## 1. Objective

Measure the frequency response of the VCO and characterize it.

## 2. Steps to follow

- Turn on equipment
  - Spectrum analyzer
  - Power supply
- Configure to desired parameters
  - Spectrum analyzer
    - Set center frequency in the middle of VCO output band (6250MHz)
    - Set span to match the VCO output band (1400MHz)
    - Set RBW and VBW to an adequate level
  - Power supply
    - Set Voltage to 3.3V
    - Set current limit to 0.3A
- Set up nucleo board and PC
  - Make sure the proper code is loaded into the nucleo board
  - Set up PuTTY
    - Select the serial port terminal
    - Set Speed(baud) to 115200
    - Set data bits to 8
    - Set stop bits to 1
    - Turn off parity
    - Set flow control to XON/XOFF
    - Set COM port to the nucleo connected one
- Make connections
  - Connect the power supply to the payload:
    - Vcc to PoL (RED)

- GND to GND (BLACK)
- Connect the DAC output to the DAC\_In (GREEN)
- Connect the spectrum analyzer to the switched measuring pin (PURPLE)

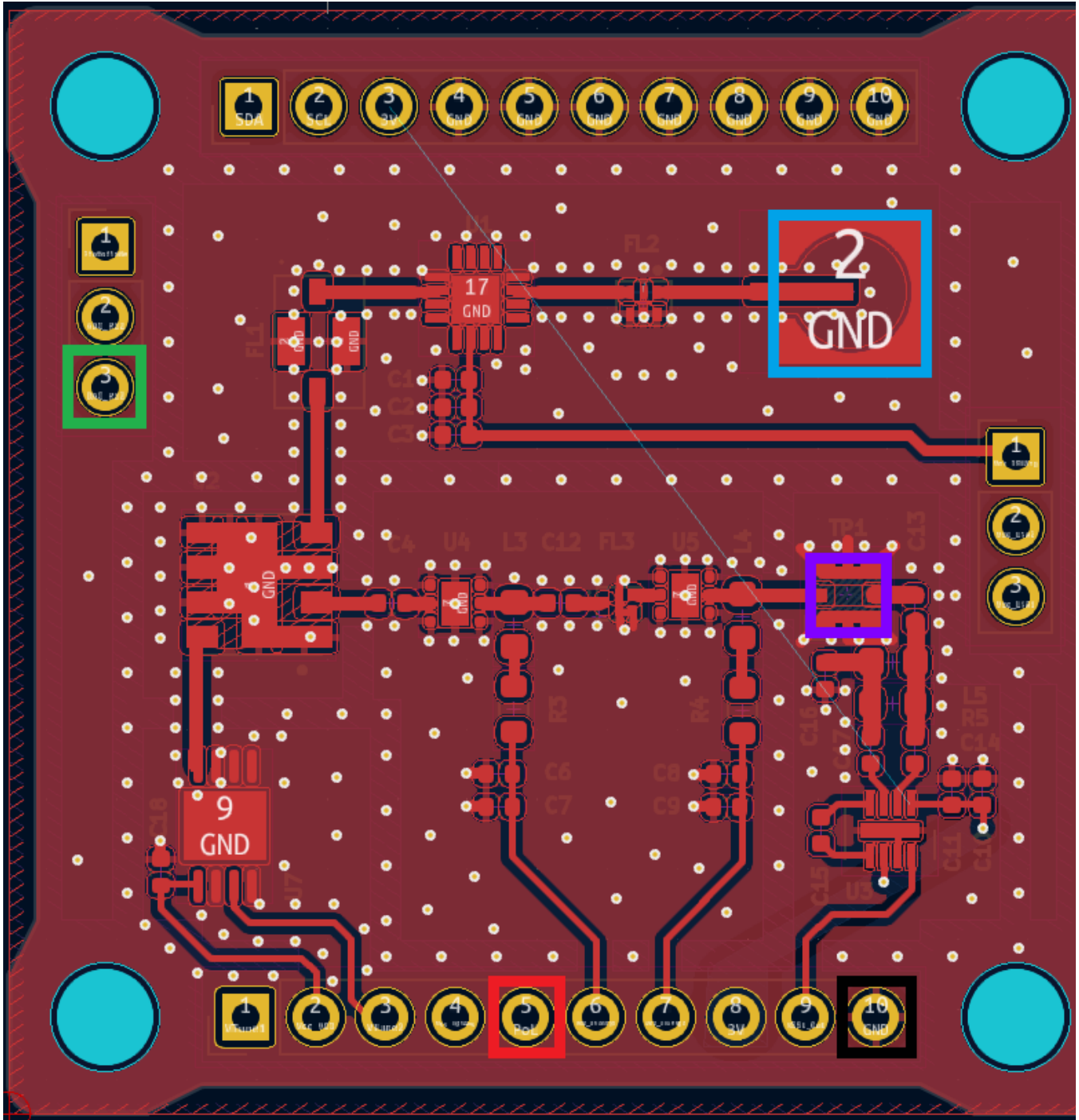

- Connect PC to ground (plug in the charger)
- Connect nucleo board to computer by USB
- Power on power supply
- Begin the measurements procedure
  - Enter frequency in PuTTY (begin on 5600 MHz)
  - Measure where the input signal peak is and annotate it
  - Annotate the deviation observed
  - Repeat these steps with  $F_{vco} \pm 50 \text{ MHz}$
- Update the VCO calibration and check it. If it's not correct repeat the previous step

Revision #1

Created 15 November 2024 18:28:13 by roger.almirall

Updated 15 November 2024 18:53:04 by roger.almirall