

K-band Noise floor characterization Procedure

1. Objective

Measure the RSSI obtained through all the 1GHz band with only noise and characterize it.

Steps to follow

- Turn on equipment
 - Spectrum analyzer
 - Power supply
- Configure to desired parameters
 - Spectrum analyzer
 - Set center frequency in the middle of RSSI input band (869MHz)
 - Set enough span to observe the RSSI input band (30MHz)
 - Set RBW and VBW to an adequate level
 - Power supply
 - Set Voltage to 3.3V
 - Set current limit to 0.3A
- Set up nucleo board and PC
 - Make sure the proper code is loaded into the nucleo board
- Make connections
 - Connect the power supply to the payload:
 - Vcc to PoL (RED)
 - GND to GND (BLACK)
 - Connect the DAC output to the DAC_In (GREEN)
 - Connect the ADC input to the ADC_Out
 - Load the IF Input with a 50 Ohm perfectly matched load.
 - Connect the spectrum analyzer to the switched measuring pin (PURPLE)

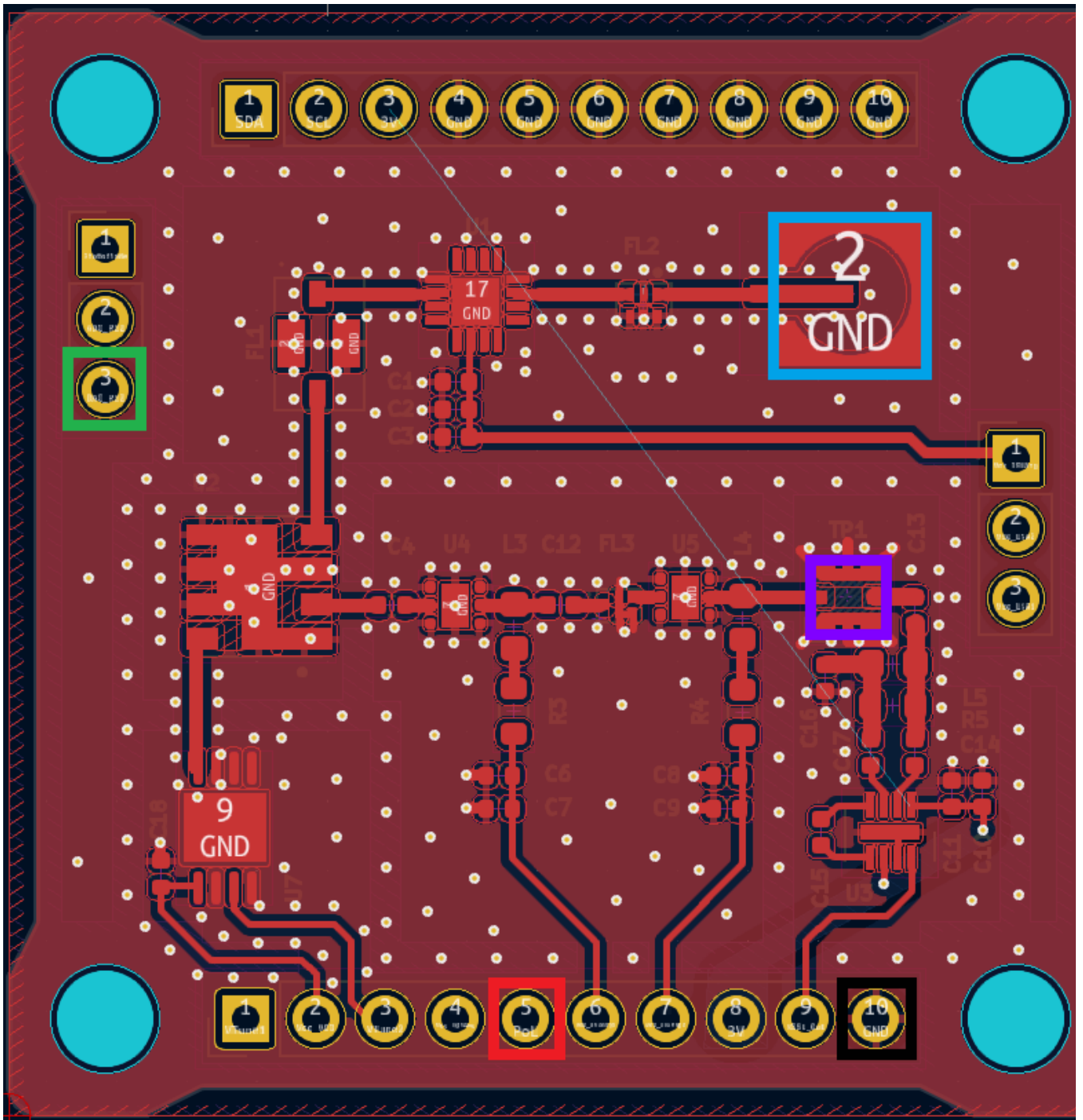

- Connect PC to ground (plug in the charger).
- Connect necleo board to computer by USB.
- Power on power supply.
- Begin the measurements procedure
 - Run the flashed program in Debug mode.
 - Measure the signal observed with the spectrum analyzer.
 - Disconnect the spectrum analyzer connected to the switched measuring pin (PURPLE).
 - Once the program stops at the breakpoint, collect the calculated mean and plot it in a data processing software like Matlab.
- Analyze the collected data.

Revision #1

Created 15 November 2024 18:29:45 by roger.almirall

Updated 15 November 2024 18:53:04 by roger.almirall